

On the Mechanism of Time-Delayed Feedback Control

Wolfram Just*, Thomas Bernard, Matthias Ostheimer, Ekkehard Reibold†, and Hartmut Benner‡
Institut für Festkörperphysik, Technische Hochschule Darmstadt, Hochschulstraße 6, D-64289 Darmstadt, Germany
 (November 15, 1996)

The Pyragas method for controlling chaos is investigated in detail from the experimental as well as theoretical point of view. We show by an analytical stability analysis that the revolution around an unstable periodic orbit governs the success of the control scheme. Our predictions concerning the transient behaviour of the control signal are confirmed by numerical simulations and an electronic circuit experiment.

PACS numbers: 05.45.+b, 02.30.Ks, 07.50.Ek

I. INTRODUCTION

The problem of controlling unstable motion is a classical subject in engineering science. The revived interest of physicists in this subject, however, started with the observation that a large number of unstable periodic orbits embedded in chaotic attractors can be stabilized by weak external forces [1]. Since that time a real industry on chaos control has developed [2]. Two main methods for controlling unstable motions have been established meanwhile. The first one, developed by Ott, Grebogi, and Yorke [1], is based on the invariant manifold structure of unstable orbits. It is theoretically well understood, but difficult to apply to fast experimental systems. The second one, proposed by Pyragas [3], uses time-delayed controlling forces. In contrast to the former one it can easily be applied to real experimental situations, but so far the control mechanism has been poorly understood from a theoretical point of view. By performing an analytical linear stability analysis we demonstrate which class of orbits is accessible to time-delayed feedback control methods. In addition, we obtain explicit expressions for important quantities like the critical and optimal control amplitude or the dependence of the transient behaviour on the control parameters.

II. THEORETICAL APPROACH

We consider a dynamical system which is described by a general set of differential equations. It may contain a periodic explicit time dependence.

$$\dot{\mathbf{x}} = \mathbf{f}(\mathbf{x}(t), t) \quad (1)$$

We are interested in the stabilization of an unstable periodic orbit $\boldsymbol{\xi}(t) = \boldsymbol{\xi}(t + \tau)$. τ is an integer multiple of the period of the driving force for non-autonomous systems. We remind the reader that the linear stability analysis of such an orbit according to $\mathbf{x}(t) = \boldsymbol{\xi}(t) + \exp[(\lambda + i\omega)t]\mathbf{u}(t)$ leads to a Floquet problem, where the exponent and the periodic eigenfunction $\mathbf{u}(t) = \mathbf{u}(t + \tau)$ are determined by

$$[\lambda + i\omega]\mathbf{u}(t) + \dot{\mathbf{u}} = D\mathbf{f}(\boldsymbol{\xi}(t), t)\mathbf{u}(t) \quad , \quad (2)$$

with $D\mathbf{f}$ denoting the Jacobian matrix of \mathbf{f} . Since our subsequent analysis applies separately to each Floquet exponent we refrain from numbering the different branches. The real and the imaginary parts of the Floquet exponents govern the instability and the revolution of the trajectory around the unstable periodic orbit (cf. fig.1).

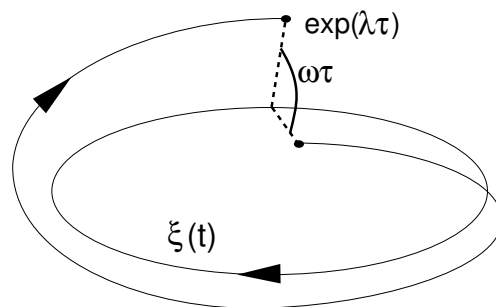

FIG. 1. Diagrammatic view of a trajectory in the vicinity of an unstable periodic orbit.

In order to achieve control of the unstable periodic orbit the system (1) is, following the idea of [3], subjected to a time-delayed force $K[\mathbf{x}(t) - \mathbf{x}(t - \tau)]$. The most general situation is given by

$$\dot{\mathbf{z}} = \mathbf{F}(\mathbf{z}(t), K[\mathbf{z}(t) - \mathbf{z}(t - \tau)], t) \quad , \quad (3)$$

where the right-hand side obeys the constraint $\mathbf{F}(\mathbf{z}, 0, t) = \mathbf{f}(\mathbf{z}, t)$, and the amplitude K of the controlling force is introduced for convenience. As long as the delay time coincides with the period of the unstable periodic orbit the controlled system admits the same solution $\mathbf{z}(t) = \boldsymbol{\xi}(t)$. Linear stability analysis according to $\mathbf{z}(t) = \boldsymbol{\xi}(t) + \delta\mathbf{z}(t)$ yields

$$\delta\dot{\mathbf{z}} = D_1\mathbf{F}(\boldsymbol{\xi}(t), 0, t)\delta\mathbf{z}(t) + D_2\mathbf{F}(\boldsymbol{\xi}(t), 0, t)K[\delta\mathbf{z}(t) - \delta\mathbf{z}(t - \tau)] \quad , \quad (4)$$

*e-mail: wolfram@arnold.fkp.physik.th-darmstadt.de

†e-mail: reibold@exp1.fkp.physik.th-darmstadt.de

‡e-mail: benner@hrzpub.th-darmstadt.de

where $D_i \mathbf{F}$ denotes the Jacobian matrix with respect to the i^{th} (vector type) argument. In the case of conventional Pyragas control, where only one system variable is assumed to be accessible, the matrix $D_2 \mathbf{F}$ contains only one non-vanishing element on the diagonal. But we keep our approach as general as possible. The (infinite dimensional generalization of) Floquet theory [4] tells us that the deviations obey $\delta \mathbf{z}(t) = \exp[(\Lambda + i\Omega)t] \mathbf{v}(t)$ and $\mathbf{v}(t) = \mathbf{v}(t + \tau)$, so that eq.(4) reduces to

$$\begin{aligned} & [\Lambda + i\Omega] \mathbf{v}(t) + \dot{\mathbf{v}} \\ & = A [K (1 - \exp[-\Lambda\tau - i\Omega\tau]), t] \mathbf{v}(t) \quad . \end{aligned} \quad (5)$$

Here the abbreviation

$$A[\kappa, t] := D\mathbf{f}(\boldsymbol{\xi}(t), t) + D_2 \mathbf{F}(\boldsymbol{\xi}(t), 0, t) \kappa \quad (6)$$

has been used. From eq.(5) it is obvious that $\Lambda + i\Omega$ can be expressed in terms of the Floquet exponents of the matrix (6). If we denote the latter for convenience by $\Gamma[\kappa]$ then eq.(5) implies the relation

$$\Lambda + i\Omega = \Gamma [K (1 - \exp[-\Lambda\tau - i\Omega\tau])] \quad . \quad (7)$$

This expression, which in fact is not entirely new but has been evaluated only numerically for specific examples (cf. [5,6]), determines the exponents of the controlled orbit in dependence of the control amplitude K . Although it is in general a difficult task to obtain a closed analytical expression for the quantity Γ , we know by definition that the boundary condition (cf. eqs.(2) and (6))

$$\Gamma[0] = \lambda + i\omega \quad (8)$$

holds, and that Γ is an analytical function as long as the Floquet exponents are non-degenerate. These properties are sufficient to conclude that only orbits with a finite frequency $\Omega \neq 0$ can become stable. On increasing the control amplitude K the real part of the Floquet exponent Λ has to change its sign from positive to negative values in order to achieve stabilization. But if the frequency Ω of the controlled orbit remains zero, the influence of the controlling force $K[1 - \exp(-\Lambda\tau)]$ vanishes if the orbit tends to become stable, so that the solutions Λ of eq.(7) never can change their sign. The reader might object that the condition $\Omega = 0$ is atypical and does not occur generically. But we remind of the fact that (nondegenerate) real Floquet multipliers are stable with respect to perturbations (cf. [7]), so that both cases $\Omega = 0$ and $\Omega \neq 0$ occur in a sense with equal probability. However one should keep in mind that the necessary condition $\Omega \neq 0$ for stabilization has to be fulfilled for each Floquet branch separately. Hence stabilization may be unlikely if the unstable manifold is high-dimensional.

We summarize that *by the Pyragas method only orbits with a finite torsion can be stabilized*, since for stabilization the influence of the controlling force has to be finite

(cf. fig.1). This property has been observed recently even in high-dimensional dynamical systems by analysing the transient behaviour of the control signal [8], but no explanation has been proposed. From this point of view the control methods by Ott, Grebogi, and Yorke on the one hand and by Pyragas on the other hand are complementary, since the former is not in principle but in most practical applications restricted to the case of only one unstable eigendirection, whereas the latter requires mostly a two-dimensional unstable manifold.

For further quantitative investigations some information about $\Gamma[\kappa]$ is required. There are a few cases where by inspection the κ -dependence can be read off from eq.(6):

$$\begin{aligned} D_2 \mathbf{F}(\boldsymbol{\xi}(t), 0, t) & = 1 \\ & \Rightarrow \Gamma[\kappa] = \lambda + i\omega + \kappa \end{aligned} \quad (9)$$

$$\begin{aligned} D_2 \mathbf{F}(\boldsymbol{\xi}(t), 0, t) & = D\mathbf{f}(\boldsymbol{\xi}(t), t) \\ & \Rightarrow \Gamma[\kappa] = (\lambda + i\omega)(1 + \kappa) \end{aligned} \quad (10)$$

But we do not intend to confine our analysis to these special situations (cf. [9]). Instead we suppose that the controlling force is small enough in order to neglect higher order terms in the expansion of eq.(7).

$$\begin{aligned} \Lambda + i\Omega & = \lambda + i\omega \\ & + (\chi' + i\chi'')K (1 - \exp[-\Lambda\tau - i\Omega\tau]) + \mathcal{O}(K^2) \end{aligned} \quad (11)$$

Here use has been made of relation (8), and the abbreviation $\chi' + i\chi'' := d\Gamma/d\kappa|_{\kappa=0}$ contains the details of the coupling mechanism of the controlling force. It is worth to mention that relation (11) is exactly valid for the cases described by eqs.(9), (10).

Relation (11) determines the stability of the controlled orbit in terms of the control amplitude K , the Floquet exponent of the uncontrolled orbit $\lambda + i\omega$, and the precise mechanism of the coupling χ', χ'' .

$$\begin{aligned} \Lambda & = \lambda + K\chi' (1 - \exp(-\Lambda\tau) \cos(\Omega\tau)) \\ & - K\chi'' \exp(-\Lambda\tau) \sin(\Omega\tau) \end{aligned} \quad (12)$$

$$\begin{aligned} \Omega & = \omega + K\chi' \exp(-\Lambda\tau) \sin(\Omega\tau) \\ & + K\chi'' (1 - \exp(-\Lambda\tau) \cos(\Omega\tau)) \end{aligned} \quad (13)$$

For the evaluation we confine the subsequent discussion to an uncontrolled unstable periodic orbit which just flips its neighbourhood within one period, that means to an orbit of frequency $\omega = \pi/\tau$. Such a situation appears particularly in a neighbourhood of a period doubling bifurcation. Since the corresponding Floquet exponent $\lambda + i\omega$ is located at the "boundary of the Brillouin zone", that means the corresponding multiplier is an isolated negative real number, $\Gamma[\kappa] - i\omega$ is by definition a real function at $\kappa = 0$ (cf. eq.(6)), and χ'' vanishes. For this reason $\Omega = \pi/\tau$ is a solution of eq.(13) which in that sense is an optimal value for the frequency since the effect of the

control term in eq.(12) becomes maximal. Then eq.(12) simplifies to

$$\Lambda = \lambda + K\chi'(1 + \exp(-\Lambda\tau)), \quad \Omega = \pi/\tau \quad . \quad (14)$$

Stabilization is achieved if Λ changes its sign, that means at a critical control amplitude

$$K_c = -\lambda/(2\chi') \quad . \quad (15)$$

K_c is mainly determined by the instability of the uncontrolled orbit. On further increase of the control amplitude the frequency may start to deviate from its optimal value. Formally this deviation results from a pitchfork bifurcation in eq.(13) which occurs at K_{opt}

$$1 = -K_{opt}\chi'\tau \exp(-\Lambda_{opt}\tau) \quad , \quad (16)$$

with Λ_{opt} being determined by eq.(14). Beyond K_{opt} the frequency Ω deviates from its optimal value π/τ so that the eigenvalue Λ of the controlled orbit starts to increase again with the control amplitude K . In this sense K_{opt} is the optimal value since the stability of the controlled orbit is maximal.

III. SIMULATIONS AND EXPERIMENT

In order to illustrate our theoretical considerations and to demonstrate that the features predicted are accessible from observed data, we have performed numerical simulations of the driven Toda oscillator

$$\begin{aligned} \dot{z}_1 &= z_2 \\ \dot{z}_2 &= -\mu z_2 - \alpha (\exp(z_1) - 1) + A \sin 2\pi t \\ &\quad - K [z_2(t) - z_2(t-1)] \quad . \end{aligned} \quad (17)$$

Time is measured in periods of the driving force. At $\mu = 0.8$, $\alpha = 25$, $A = 105$, and $K = 0$ the system possesses a chaotic attractor. A period-one orbit, which has become unstable in a period doubling bifurcation, can be stabilized at finite control $K > K_c \approx 2.1$. From the exponential decay of the control signal $z_2(t) - z_2(t-1)$, using a standard least square method, we determine the real and imaginary parts of the Floquet exponent $\Lambda + i\Omega$ for several values of the control amplitude. Our findings are summarized in fig.2. We clearly observe the predicted dependence on the control amplitude. Using the value $K_{opt} \approx 2.4$ we determine the two parameters λ and χ' by means of eqs.(15) and (16) and compare our simulations with the theoretical prediction from eqs.(12) and (13). The quantitative coincidence is within a few percent. This result is even more convincing when keeping in mind that the theoretical prediction is just a first order computation in the control amplitude which actually is not so small. For larger values of K we observe an additional frequency in the control signal. Such a property

can be attributed to the second (stable) Floquet branch and may also be evaluated by eq.(7). Finally, as a by-product, we obtain an estimate of the Floquet exponent $\lambda + i\omega$ of the uncontrolled orbit.

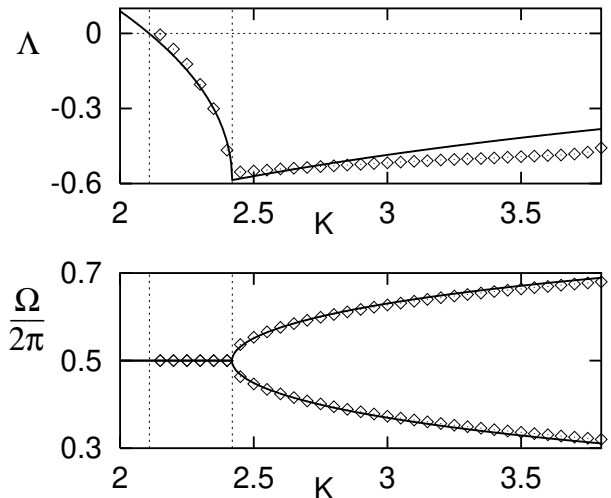

FIG. 2. Real and imaginary part of the Floquet exponent for a numerical simulation of eqs.(17). The data (symbols) have been obtained from the decay of the control signal on variation of the control amplitude K . The solid lines indicate the analytical solutions of eqs.(12) and (13) with $\lambda \approx 0.97$, $\chi' \approx -0.23$.

In addition to analytical calculations and computer simulations we have performed experiments on a nonlinear electronic circuit (see e.g. [10]). We consider a nonlinear diode resonator consisting of a capacity diode (1N4005), an inductor ($470\mu\text{H}$), and a resistor (40Ω) (cf. fig.3).

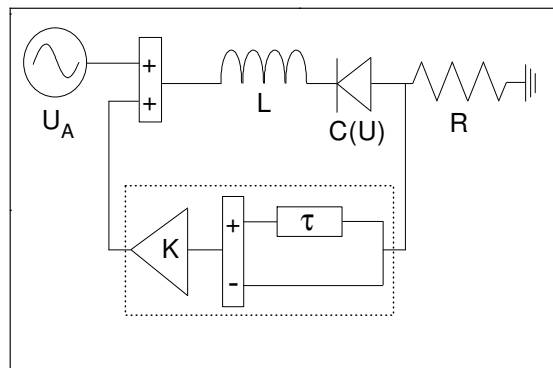

FIG. 3. Experimental setup of the nonlinear diode resonator with time-delayed feedback device.

The control device consists of a cascade of electronic delay lines with a limiting frequency of about 2MHz and several operational amplifiers acting as preamplifier, subtractor, or inverter. The device allows to apply a controlling force of the form $\pm K[U(t) - \epsilon U(t - \tau)] + U_0$ with parameter ranges $K = 0 \dots 300$, $\epsilon = 0 \dots 2$, $\tau =$

10...7000ns, and $U_0 = -5 \dots + 5V$. For conventional delayed feedback control ϵ has carefully to be adjusted to one and the offset U_0 to zero. This was done in the experiment reported here. The circuit was sinusoidally driven with an amplitude of 2V and a frequency of 990kHz. Accordingly the delay time was set to $\tau = 1010$ ns. From the transient dynamics of the control signal we again obtain the decay rate and the frequency (cf. fig.4). For comparison with the theoretical prediction we take the values $K_c \approx 34$ and $K_{opt} \approx 37.5$ to determine the two parameters $\chi'\tau$ and $\lambda\tau$ from eqs.(15) and (16). The quantitative agreement with eqs.(12), (13) is within a few percent, except for the real part beyond K_{opt} .

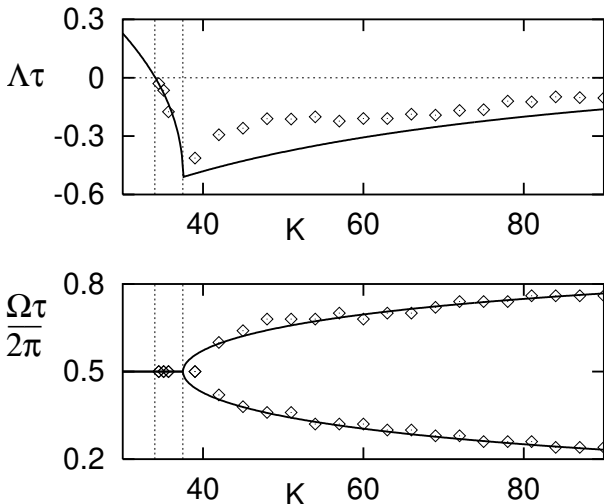

FIG. 4. Real and imaginary part of the Floquet exponent for the electronic circuit experiment. The data (symbols) have been obtained from the decay of the control signal on variation of the control amplitude K . The solid lines indicate the analytical solutions of eqs.(12) and (13) with $\lambda\tau \approx 1.09$, $\chi'\tau \approx -0.016$.

Apart from the reasons already mentioned the deviations can be attributed to the limited accuracy of the value K_{opt} . Since the transients are affected by noise a precise estimate of the exponents is difficult to obtain for small decay rate Λ .

IV. CONCLUSION

We have shown that the main limiting factor for time-delayed feedback control results from the torsion of the unstable periodic orbit. This topological property determines whether the control mechanism works at all. We have worked out the general features of the transient behaviour including critical and optimal control amplitudes. Our approach describes at least the generic properties for stabilizing unstable periodic orbits with an unstable manifold like a Möbius strip. Our simulations have shown that the features described above are acces-

sible from the transient behaviour of the control signal and hence are observable in experiments. The electronic circuit experiment demonstrates that an analysis along these lines is possible even for ultrafast experiments. Our theoretical approach, based on an expansion of the general expression (7), resembles a Ginzburg–Landau like treatment of phase transitions. It can be easily extended to incorporate e.g. the degeneracy of several Floquet exponents or the features of spatially extended, that means high-dimensional systems.

V. ACKNOWLEDGEMENT

This project of SFB 185 "Nichtlineare Dynamik" was partly financed by special funds of the Deutsche Forschungsgemeinschaft.

-
- [1] E. Ott, C. Grebogi, and Y. A. Yorke, *Phys. Rev. Lett.* **64**, 1196 (1990).
 - [2] W. L. Ditto, S. N. Rauseo, and M. L. Spano, *Phys. Rev. Lett.* **65**, 3211 (1990); E. R. Hunt *Phys. Rev. Lett.* **67**, 1953 (1991); L. M. Pecora and T. L. Carroll, *Phys. Rev. A* **44**, 2374 (1991); B. Hübinger, R. Doerner, and W. Martienssen, *Z. Phys. B* **90**, 103 (1993); C. Reyl, L. Flepp, R. Badii, and E. Brun, *Phys. Rev. E* **47**, 267 (1993); A. Kittel, J. Parisi, K. Pyragas, and R. Richter, *Z. Naturf. A* **49**, 843 (1994).
 - [3] K. Pyragas, *Phys. Lett. A* **170**, 421 (1992).
 - [4] J. Hale, *Theory of Functional Differential Equations*, Springer New York, 1977, p. 195f.
 - [5] K. Pyragas, *Phys. Lett. A* **206**, 323 (1995).
 - [6] M. E. Bleich and J. E. S. Socolar, *Phys. Lett. A* **210**, 87 (1996).
 - [7] J. Guckenheimer and P. Holmes, *Nonlinear Oscillations, Dynamical Systems, and Bifurcations of Vector Fields*, Springer New York 1986, p. 29f.
 - [8] C. Simmendinger and O. Hess, *Phys. Lett. A* **216**, 97 (1996).
 - [9] T. Bernard, R. Henn, W. Just, E. Reibold, F. Rödelsperger, and H. Benner, in *Nonlinear Microwave Signal Processing: Towards a New Range of Devices*, Ed. R. Marcelli, Kluwer Acad. Publ. 1996, p. 373–400.
 - [10] T. Carroll and L. Pecora, *Nonlinear Dynamics in Circuits*, World Scientific, 1995.